

# User Manual for

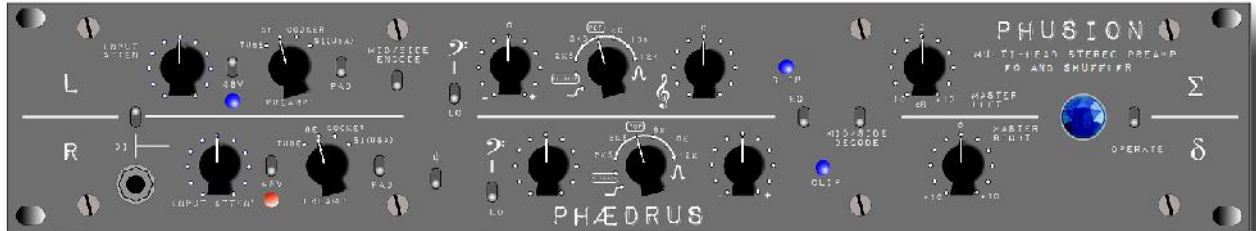

## **PHUSION** MULTI-HEAD STEREO PREAMPLIFIER, EQ AND SHUFFLER

This manual is also available as a pdf download, Go to: [www.phaedrus-audio.com](http://www.phaedrus-audio.com)

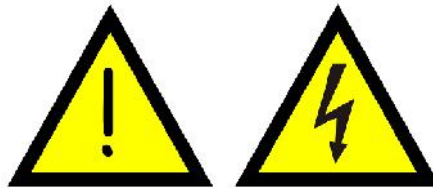

RISK OF ELECTRIC SHOCK  
DO NOT OPEN!



# Chapter 1 - Background

The new PHÆDRUS AUDIO PHUSION is a 2RU, mains-powered unit. The PHÆDRUS AUDIO PHUSION is a recreation of two entire channel strips, derived from famous circuits in the classic mixers of the 1950s and the 1960s.

Features include:

- 2 Tube preamps
- 2 British germanium preamps
- 2 *Orthophonic* preamp circuits (*Cookers*)
- 2 American silicon-preamps
- 2 Classic LC passive equalisers
- $\Sigma$ - $\delta$  processing for Stereo Shuffling and for *elliptical* (sum-difference) equalisation
- 2 studded, rotary faders (2dB step)

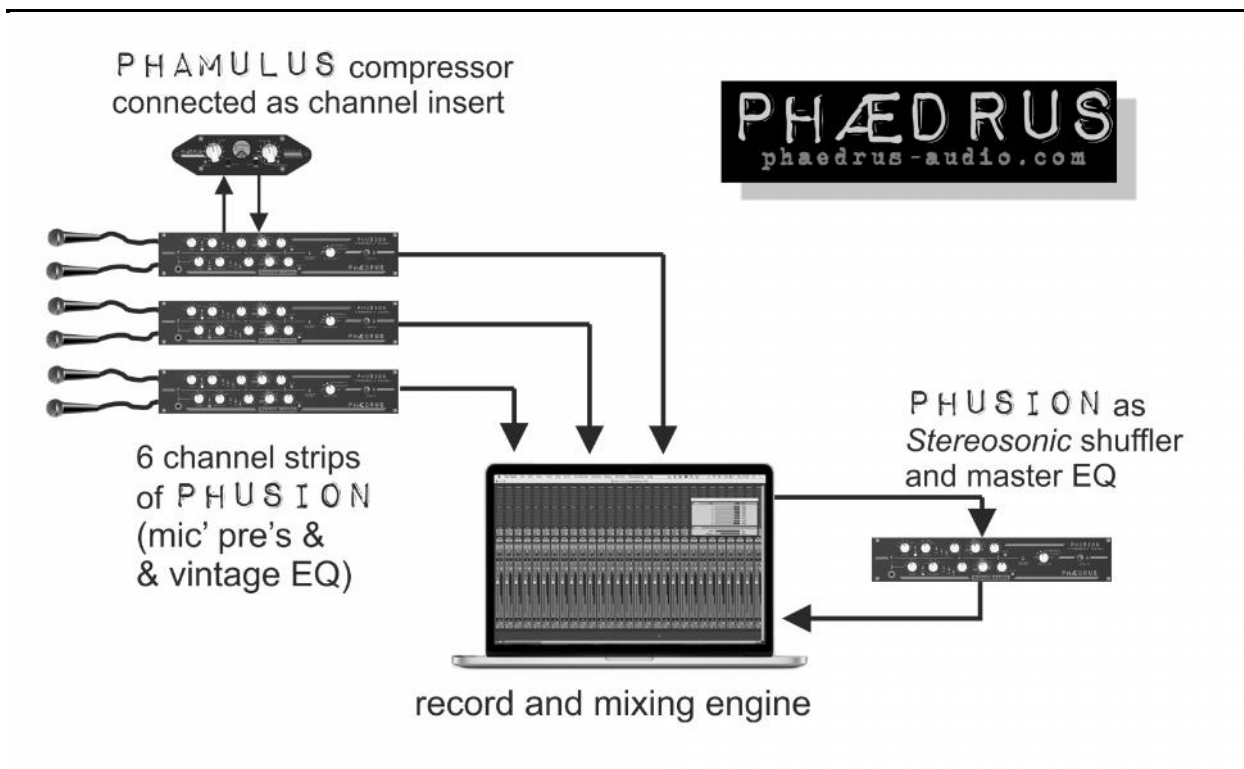

The PHUSION has applications in tracking, mixing and mastering.

## RECORDING/TRACKING

With its classic microphone amplifiers, EQ and DI circuitry, there's no signal that can't be enhanced and positively "tweaked" with the PHUSION. The sum-difference processing provides for decoding stereo signals from spaced omnis (Blumlein Delta technique) as well as mid-side microphone arrangements.

## MIXING

Each PHUSION is a full two channel strips of a classic console. Four together, feeding a modern mixer (used just for pans and faders) recreates a full, 8-channel tube, germanium or silicon solid-state console. This is the most cost effective way ever to re-create a classic console. And you can even mix and match having tube stages on channels I & II, germanium of II & IV for example.

## MASTERING

The PHUSION also incorporates sum/difference (Mid/Side) encoding and decoding so that the equalisers (and the compressors if they are connected at the insert points) may be used as mid/side processors, rather than across the left and right signals. Ideal for mastering for better impact, or for LP.

## Chapter 2 - Warranty and Service

Please refer to for the latest information and advice about warranty and service at:  
[http://www.phaedrus-audio.com/phaedrus\\_t&cs.htm](http://www.phaedrus-audio.com/phaedrus_t&cs.htm)

## Chapter 3 - Safety

### General

Before using any piece of equipment manufactured by Phædrus Audio, be sure carefully to read the applicable items of these operating instructions and the safety suggestions. Keep them for future reference. Follow the warnings indicated on the unit, as well as in the operating instructions.

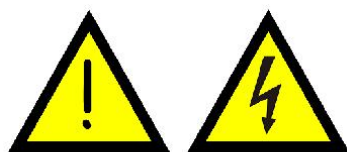

RISK OF ELECTRIC SHOCK  
DO NOT OPEN!

### User Access & Servicing

Phædrus Audio equipment employs thermionic valve (vacuum-tube) technology and employs hazardous voltages for the high-tension supplies. THE USER SHOULD NOT ATTEMPT TO SERVICE THE UNIT. ALL SERVICING SHOULD BE REFERRED TO QUALIFIED SERVICE PERSONNEL OR FACTORY ONLY.

Phædrus Audio products should NEVER be connected to the external power supply or in any other way energised when the case is opened and/or the circuit board is accessible.

### General Safety Instructions

- Do not operate Phædrus Audio equipment near any source of water or in excessively moist environments.
- Keep your Phædrus Audio equipment away from babies, children and pets.

- Do not let objects do not fall, or liquids be spilled, into the enclosure.
- Situate the Phædrus Audio equipment away from heat sources or other equipment that produce heat.
- Ensure Phædrus Audio equipment has adequate ventilation. Improper ventilation will cause overheating, and can damage the equipment.
- When cleaning Phædrus Audio equipment, remove all connections to the unit; including power and gently wipe with a clean lint-free cloth; if necessary, gently moistened with lukewarm or distilled water. Use a dry lint-free cloth to remove any remaining moisture. NEVER use aerosol sprays, solvents, or abrasives on Phædrus Audio equipment.
- Phædrus Audio equipment should be serviced by qualified service personnel or returned to Phædrus Audio Ltd. when: an object (or objects) have fallen into the enclosure; or liquid has fallen into, or been spilled into the unit; or the unit has been exposed to rain or high humidity; or the unit does not operate normally or exhibits a marked change in performance; or the unit has been dropped, or the enclosure has been damaged.

## Chapter 4 - Instructions for use

Phædrus Audio's products employ valves (vacuum tubes) in the audio path. Valves (vacuum tubes) and their associated circuitry need time to reach an electronic equilibrium before they will operate at optimal specifications. Please therefore allow these products to warm up for, at least, 5 to 10 minutes before using them in your signal chain. To prolong the life of your valves (tubes), it is recommended that you turn off these units when not in use.

### Application and connections

Typical connection schemes for the PHUSION are illustrated in Chapter 1. The signal processing architecture of the PHUSION is best explained with reference to a block diagram as illustrated below.

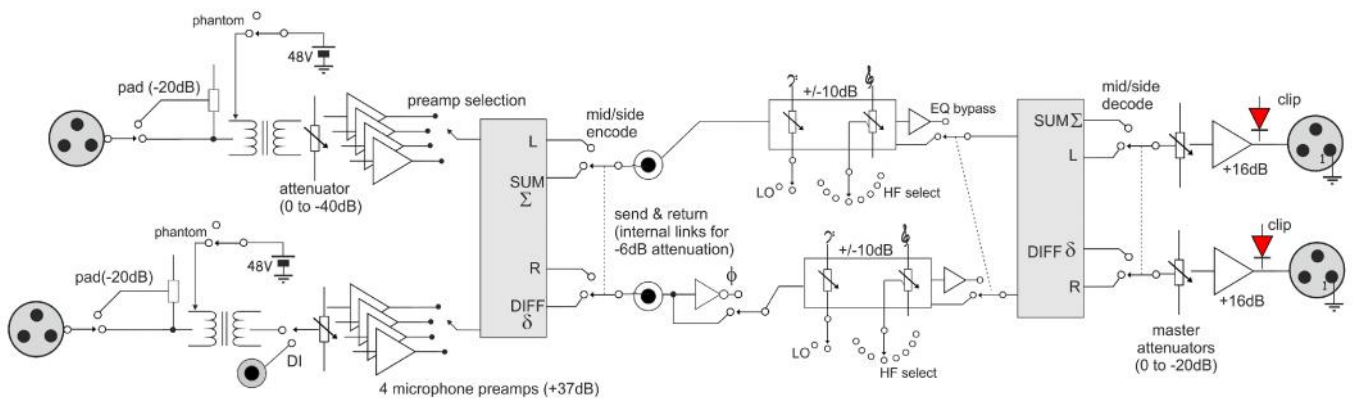

**Architecture of the PHUSION**

## Input stage controls

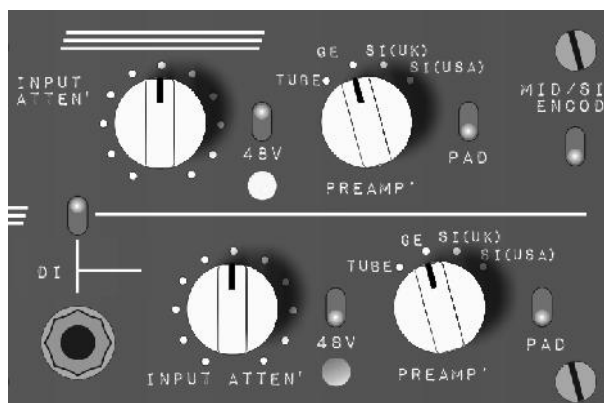

The input stage controls consist of: the DI switch (right/ side channel only); the input attenuation controls (both channels); the phantom power switches; the preamplifier selection switches; and the pad switches.

The DI switch routes the signal on the front-panel jack to the preamplifiers. This control is only present on the right/side channel.

The input attenuation controls are precision, stepped attenuators maximum attenuation (at anti-clockwise end-stop) is 40dB.

The phantom power switches route 48V to the microphone inputs. **Please observe the usual precautions when selecting phantom power.**

The preamplifier selection switch selects which of the four microphone preamplifiers will amplify the DI (right channel) or microphone signal. The options are: Tube preamp; British germanium transistor preamp, British modified hi-fi transistor preamp (*Cooker*); American early op-amp preamp. More information is given on each of these preamplifiers in Chapter 6.

The Pad switch introduces 20dB attenuation on the primary side of the input transformer.

## Mid/side encode & decode

The mid/side switch encodes the following signal path so that the upper channel operates on the sum of the two input signals  $(L + R) / \sqrt{2}$  and the lower channel operates on the difference-signal  $(L - R) / \sqrt{2}$ . (For an explanation of these constants see Appendix 1.)

This signal-processing provides a number of signal processing options which are described below, but the principal function is to force the equalisation section and the send-return loop to operate across the sum/difference channels rather than across the primary right & left signals. The various advantages of this approach are explained below in the equalisation section.

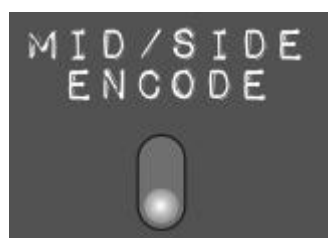

Note that the output of the unit will remain sum & difference unless the corresponding mid/side decode switch is operated as well. This control decodes the sum & difference signal so that the output returns to right & left.

## Operating with mid/side microphone arrays

The mid/side decode and encode switches may be used when operating with mid/side microphone arrays. If the encode switch is selected when the inputs are mid/side, the EQ controls (and send-return loop) will work across the left & right signal in the time-honoured way. If however, the encode switch is left in the off position and the *decode* switch is selected, then the EQ controls (and send-return loop) will continue to work on the mid/side signals. This offers great creative freedom. In either case, the output signals will be left & right. Note that the phase switch will have the useful effect of reversing left & right output signals when they are derived from mid/side array.

## Phase invert control

The phase invert control inverts the phase of the lower channel. This has applications anytime two microphones are being used. In a mid-side configuration, the phase switch will have the useful effect of reversing left & right output signals.

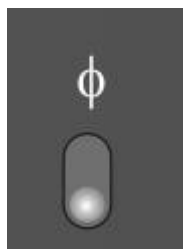

## Equalisation controls

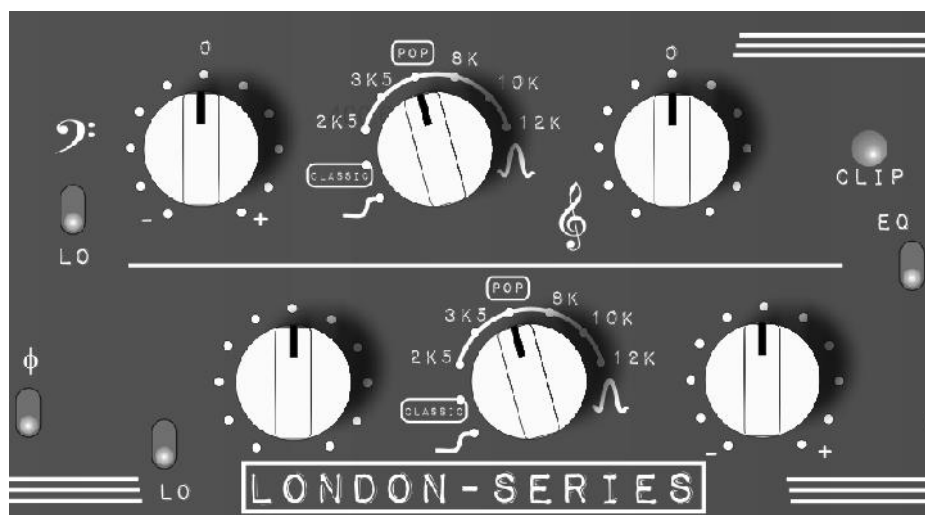

The equalisation controls on the PHUSION are simple and intuitive to operate. When the middle frequency-control is turned to the two most anti-clockwise positions, the bass and treble controls (marked with the appropriate music clefs) act as they do on a shelving

equaliser; as a boost and cut control: clockwise to boost (in 2dB steps); anti-clockwise to cut (in 2dB steps).

The central control may be used to modify the character of the treble-frequency boost. Depending on the frequency setting: 2.5kHz; 3.5kHz; 5kHz; 8kHz; 10kHz; 12kHz, when the treble control is rotated clockwise beyond the central position, boost is applied with a broad peak in the response at the indicated frequency. Note that this control is NOT active when treble-frequency cut is applied; this always remains as a shelving response. The graph below illustrates the 121 separate response curves which result from the 121 combinations of treble and bass control when the central switch selects the 5kHz, peaking-response. Note that the cut curves do not exhibit a complementary notch to the boost peak.

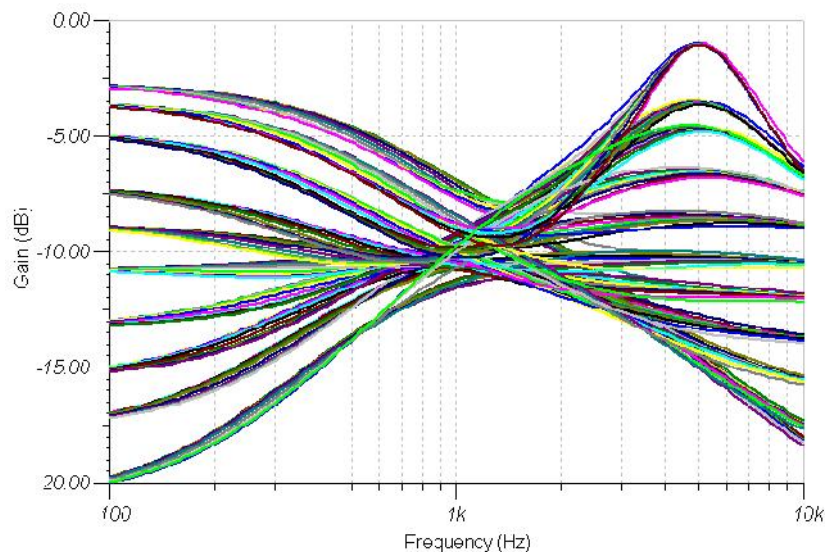

## Sum & difference operation

As explained above, the PHUSION has circuitry which encodes the signal path so that the upper channel operates on the sum of the two input signals  $(L + R)/\sqrt{2}$  and the lower channel operates on the difference-signal  $(L - R)/\sqrt{2}$ .

The operational advantages of this are legion because the EQ controls may now be used to equalise the centre or the side components of a stereo mix. For example, the bass-drum and bass (mixed centre) may be made more “punch” without generating “boom” in the reverb components of the mix. Similarly, the reverb may be made more “airy” without making the main singer or instrumentalist “brash” or “toppy”.

## Stereo Shuffling

(For information and history on Stereo Shuffling go here: [http://www.phaedrus-audio.com/intro\\_to\\_shuphlers.htm](http://www.phaedrus-audio.com/intro_to_shuphlers.htm))

Equalisation in the sum & difference path also allows you to explore important and powerful **stereo-shuffling** techniques.

Stereo shuffling is applied by operating the tone controls on the ***difference signal alone (the sum channel should be left flat)***. Selecting a small degree of shelving treble-cut (two-stops) in the difference channel will implement classic shuffling (invented by the EMI Stereosonic team). This shuffling technique improves stereo imaging.

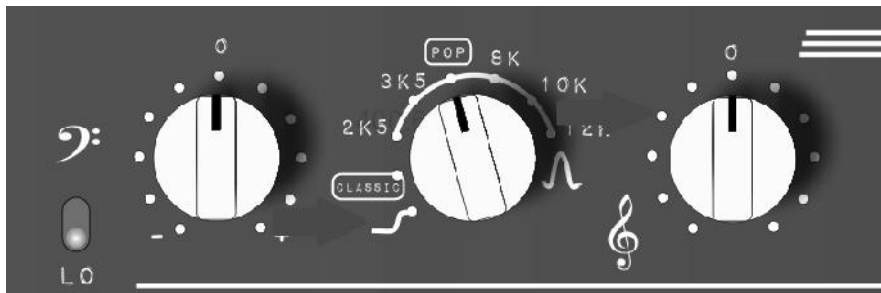

**Control settings (delta channel only) for classic Stereosonic shuffling**

Applying maximum bass-boost in the difference-channel implements Blumlein shuffling and permits the use of close spaced omni microphones for stereo recording. This technique is sometimes called Blumlein Difference Technique (see [http://www.phaedrus-audio.com/intro\\_to\\_shupplers.htm](http://www.phaedrus-audio.com/intro_to_shupplers.htm) for more details about this stereo microphone technique).

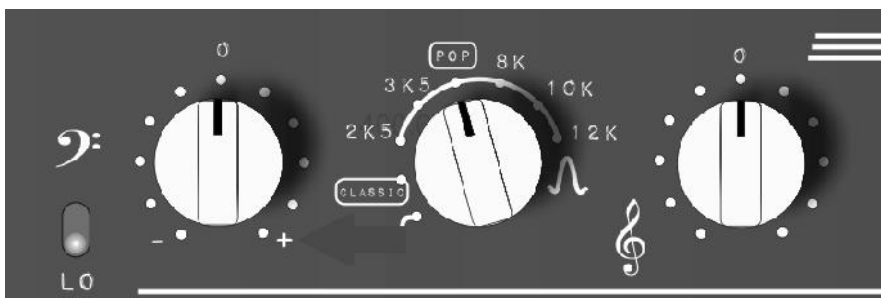

**Settings for Blumlein (difference technique) shuffling**

## LO switch

The LO switch reduces the frequency over which the bass-boost is applied so that boost is only applied below about 200 Hz. Compare the boost/cut curves below with the curves shown above.

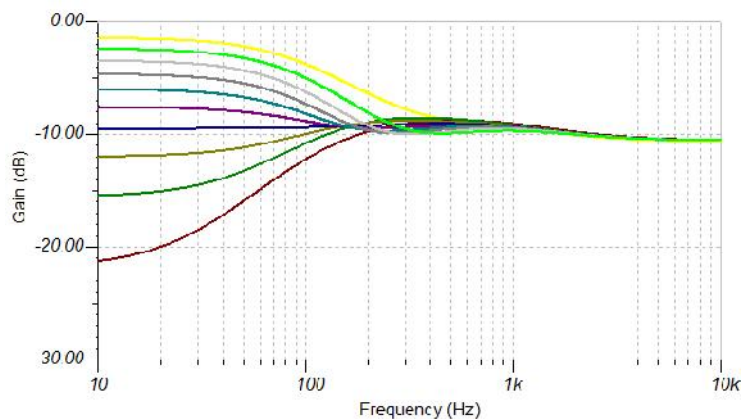



## EQ bypass switch

In many situations, it's very useful to be able to judge equalisation by A-B-ing the equalised and non-equalised signal. This is the function of the EQ bypass switch which entirely bypasses the equalisation circuits. Note that this switch bypasses the EQ on both channels.

## Send-Return loop

The send return loop of the PHUSION is between the mid/side encode and decode. This means that the send-return loop may be forced to operate on the sum and difference signals instead of the normal left & right signals. This is the ideal position for compression to be applied (for example the PHAMULUS vari-mu compressor).

Sum and difference processing was a technique much used prior to the introduction of digital media because a stereo gramophone encodes stereo information as a sum-signal which modulates the lateral (side-to-side) movement of the stylus: and a difference-signal, which modulates the vertical movement of the stylus. This is illustrated below.

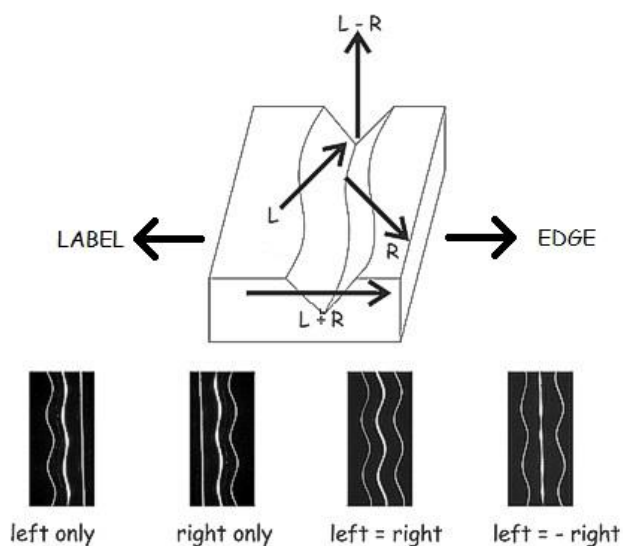

Applying compression across the derived sum and difference signals offers great creative freedom and the ability to balance direct and reverberation signal in ways quite impossible via normal left & right processing.

## Master faders

The master faders are equivalent to the channel faders on a mixer. The inclusion of these controls allows you to, for example, to reduce the signal level at the master fader point, so that you can drive the channel harder. This is especially significant given the choice of microphone preamplifiers because they all overload differently as explained in Chapter 6.

Signal levels should be set using the blue-red overload indicator controls. The default setting for these controls is 12-o'clock.

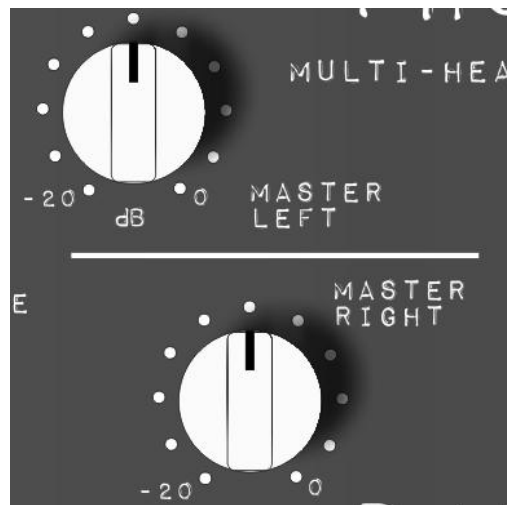

## Operating levels & overload indicator

To prevent inadvertent clipping, the PHUSION contains a clip detect circuit which turns the normally blue LEDs red when the audio level is 3dB below peak. This indicator should only be allowed to flash red occasionally in operation. The PHUSION operates at the standard recording industry level of +4dBu=0VU.

## Chapter 6 - Circuit descriptions

The PHUSION is equipped with four microphone preamplifiers for each channel. They are: a classic tube preamp; British germanium transistor preamp, British modified hi-fi transistor preamp; American discrete op-amp preamp. Each has a very different character.

### Tube preamp



The tube (valve) preamplifier is the oldest of the designs and has its origins in the nineteen-forties. Based on the RCA BA-2C, this circuit has a “warm & big” sound. We use a dual triode for each channel, the two parts of which exactly match the two 6J7 pentodes (run as triodes) in the original design. The RCA circuit was a standard design reference and is believed to be at the heart of many of the classic, studio-built tube consoles of the late fifties and sixties such as the famous console used to record The Kinks in PYE Studio 2 in Cumberland Place, London.

## The British germanium preamplifier

This preamplifier is a re-creation of the mic' preamp in the first, transistorised, professional console anywhere in the world, which was built by Dick Swettenham for the original Olympic Sound Studios in Carlton Street, London. This landmark console was the desk used to record the early The Jimi Hendrix Experience tracks and The Rolling Stones first single, "Come On". The circuit employs only, new-old-stock (NOS) germanium transistors. The character is relatively "soft". If driven hard, this circuit will slew-rate limit causing an overload character all of its own.



## Orthophonic preamplifier (*The Cooker*)

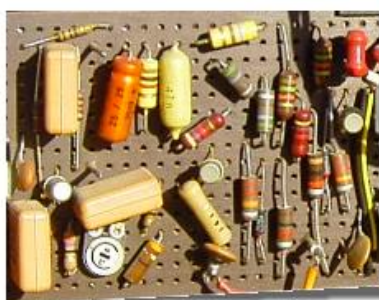

From the august pages of the British amateur electronics magazine *Wireless World*, this third preamplifier was designed to do double-duty as a phonograph (**Orthophonic** curve) preamplifier and a microphone preamp'. True to its amateur background, the circuit does not respect "professional" levels and impedances and may be driven further into distortion than any other preamplifier in the PHUSION.

Such a circuit was extensively used by Joe Meek who, recognising its potential as a source of creative distortion, named it *the Cooker*<sup>1</sup>.

## American solid-state preamplifier



This preamplifier has a classic west-coast sheen: the sound is "big and beautiful". The high feedback design lends this circuit that "tightness" that we associate with American consoles of the period. This circuit has good headroom, only bettered by the tube circuit.

---

<sup>1</sup> Meek himself describes the signal path thus, "The vocal mic goes through a little 'cooker' I've made..... It was originally a small amplifier". (From Bob Stanley's sleeve notes to the authoritative CD box set *Joe Meek - Portrait of a Genius* The RGM legacy, Castle Music UK, UPC: 505015917839)

# Specifications

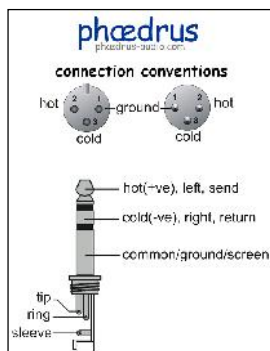

## Electrical connections

### Input:

Unbalanced: 3 pin XLR Connector      Balanced: 3 pin XLR Connector

Pin 1 – Ground      Pin 1 – Ground

Pin 2 – (+) Signal      Pin 2 – (+) Signal

Pin 3 – Connect to Pin 1      Pin 3 – (-) Signal

### Output:

Unbalanced: 3 pin XLR Connector      Balanced: 3 pin XLR Connector

Pin 1 – Ground      Pin 1 – Ground

Pin 2 – (+) Signal      Pin 2 – (+) Signal

Pin 3 – Leave o/c      Pin 3 – (-) Signal

### Send/ return:

Unbalanced: 3 pin XLR Connector

Tip – Send

Ring – Return

Sleeve - Ground

## PHUSION Specification

Input: Balanced, transformer coupled

Output: Balanced/ unbalanced (link selectable)

Gain (maximum): 53dB

Preamp attenuator: 40dB range in 4dB steps

Pad: -20dB (-30dB via internal link for PHUSION operated permanently at line-level.)

Gain post return socket: -4dB to +16dB (fader range is 20dB in 2dB steps)

Maximum level on return: +18dBu (+24dBu with internal link)

Frequency response: Preamp dependent. *American SI* setting: -3dB points at 12Hz and 66 kHz

Crosstalk (L & R mode): better than -60dB at 10kHz

EIN: 400nV RMS, -126dBu; max gain, input terminated in 200R, unweighted reading (BW 300 – 20kHz)

Maximum output level: +24dBu @ 1kHz. Clip LED indicates RED at 3dB below clipping level

Power supply: 230 AC or 110V AC (specify at time of order)

Power consumption: 20 Watts

Phantom Supply: +48V DC, up to 5mA

Phaedrus Audio Ltd. reserves the right to alter these specifications without notice.

# Appendix 1

Both the encode matrix and decode matrix are implemented identically so that from the inputs **A** & **B** are derived,

$$(A + B)/\sqrt{2} \text{ and } (A - B)/\sqrt{2}$$

When the inputs are **L** & **R**, the outputs are clearly,

$$(L + R)/\sqrt{2} \text{ and } (L - R)/\sqrt{2}$$

And when the inputs themselves are these signals, the outputs are,

$$[(L + R)/\sqrt{2} + (L - R)/\sqrt{2}] = 2L / (\sqrt{2} \times \sqrt{2}) = 2L / 2 = L \quad \text{and}$$

$$[(L + R)/\sqrt{2} - (L - R)/\sqrt{2}] = 2R / (\sqrt{2} \times \sqrt{2}) = 2R / 2 = R$$

## **Declaration of Conformity**

The Manufacturer of the Products covered by this Declaration is

**Phædrus Audio Ltd.**  
**head office address**

The directives covered by this declaration are:

**89/336/EEC Electromagnetic Compatibility directive**  
**73/23/EEC Low Voltage Equipment directive**

The products covered by this declaration are:

**Phædrus Audio PHUSION**

The basis on which conformity is being declared:

The manufacturer hereby declares that the products identified above comply with the protection requirements of the EMC directive and with the principal elements of the safety objectives of the Low Voltage Equipment directive, and that the following standards have been applied:

**IEC INTERNATIONAL STANDARD 60065 - Audio, video and similar electronic apparatus – Safety requirements**

The technical documentation required to demonstrate that the products meet the requirements of the Low Voltage Equipment directive has been compiled and is available for inspection by the relevant enforcement authorities. The CE mark was first applied in 2011.



Signed:

**Richard Brice . Phædrus Audio**

Date:

August 2016